

PERSPEX<sup>®</sup>  
FROM LUCITE<sup>®</sup>

Workshop Handbook  
Verarbeitungshinweise  
Manuel d'atelier



LUCITE<sup>®</sup>  
The source of inspiration

# Workshop Handbook

<b>CONTENTS</b>	<b>PAGE</b>
<b>1.0 INTRODUCTION</b>	2
<b>2.0 PROPERTIES</b>	2
<b>3.0 ENGINEERING DESIGN DATA</b>	2
<b>4.0 BURNING BEHAVIOUR</b>	3
<b>5.0 MASKING PROTECTION</b>	3
<b>6.0 STORAGE</b>	3
<b>7.0 PREPARING FOR FABRICATION</b>	3
7.1 Cleaning	4
<b>8.0 MACHINING</b>	4
8.1 Cutting Tools	4
8.2 Sawing	4
8.3 Scribe-Breaking	5
8.4 Laser Cutting	6
8.5 Drilling	7
8.6 Screwing and Tapping	8
8.7 Turning	8
8.8 Spindle Moulding	8
8.9 Engraving	8
8.10 Routing	8
8.11 Finishing	9
<b>9.0 THERMOFORMING (GENERAL)</b>	10
9.1 Methods of Thermoforming	14
9.2 Double Curvature Thermoforming	19
9.3 Vacuum Forming	21
<b>10.0 CEMENTING</b>	22
<b>11.0 PRINTING, PAINTING AND SURFACE DECORATION</b>	23
<b>12.0 STRESS</b>	23
12.1 Annealing	24
12.2 Normalising	24
<b>13.0 SAFETY</b>	25
<b>14.0 CHEMICAL RESISTANCE</b>	26
<b>15.0 TALK TO US</b>	29
<b>16.0 APPENDIX</b>	30
16.1 List of Suppliers	30

## 1.0 INTRODUCTION

Perspex® from Lucite® acrylic sheet is a most useful material in the workshop because it can be used to make precision engineering components for both domestic and industrial products. Typical applications include signs, glazing, safety screening, roof-lighting, furniture, lighting fittings and a great many industrial parts for the medical and chemical industries. Perspex® is manufactured in two forms; cell cast and extruded sheet.

Perspex CS (cell cast) sheet is available in a wide range of thicknesses and colours, including blocks, colours and surface patterns.

Perspex XT (extruded) sheet is available as clear sheet and also in a range of opal and tinted colours and impact modified grades.

Some differences exist between Perspex CS (cast) and Perspex XT (extruded) properties arising from their molecular structure and this can be reflected in their fabrication behaviour. These differences are highlighted where appropriate in the handbook. Otherwise, fabrication behaviour may be assumed to be very similar for both products.

## 2.0 PROPERTIES OF PERSPEX FROM LUCITE

- Exceptional light transmission with virtually no colour bias - even in thick blocks.
- Excellent resistance to outdoor weathering.
- Good resistance to impact.
- A high gloss, hard surface.
- High tensile strength and rigidity.
- Easily thermoformable with simple workshop tools.
- Easy to clean.
- Capable of being fully recycled.

## 3.0 ENGINEERING DESIGN DATA

The long term mechanical performance of Perspex from Lucite will depend on temperature and applied stress and when designing engineering components these considerations must be taken into account. **Table 1** gives details of the maximum long term and short term design stress levels derived from fracture mechanics studies that can be safely applied to engineering components made from Perspex cast sheet.

**Table 1** Design data for Perspex® cast acrylic sheet at 20° C

Property	Units	Short-Term / Intermittent (6 hours)	Long Term / Continuous (10 years)
Tensile strength (unexposed)	kgf/cm <sup>2</sup>	170	88
	MPa	17	8.6
	lbf/in <sup>2</sup>	2500	1250
Tensile strength (exposed)	kgf/cm <sup>2</sup>	140	70
	MPa	14	7
	lbf/in <sup>2</sup>	2000	1000
Modulus	kgf/cm <sup>2</sup>	2.5 x 10 <sup>4</sup>	1.3 x 10 <sup>4</sup>
	GPa	2.5	1.2
	lbf/in <sup>2</sup>	3.6 x 10 <sup>5</sup>	1.8 x 10 <sup>5</sup>
Poisson's ratio		0.39	0.40

## 4.0 BURNING BEHAVIOUR

Perspex® from Lucite® is a combustible material and if ignited will continue to burn. Perspex cast acrylic sheet has a combustion rate similar to hard woods but unlike many other plastic materials burning Perspex produces very little smoke, an important fire safety benefit. Perspex XT extruded sheet has a rate of combustion similar to cast sheet but will eventually produce molten droplets which will continue to burn. For full details of the behaviour of Perspex grades to many international fire tests, please see **236, Glazing Solutions**.

## 5.0 MASKING PROTECTION

The surfaces of Perspex from Lucite are covered with a masking film for protection during transport, storage and fabrication. Perspex cast acrylic sheet is protected both sides with a pressure-sensitive adhesive backed polyethylene film.

## 6.0 STORAGE

Perspex from Lucite sheets are best stored on edge with the protective masking left in place for as long as possible. The most convenient method of storage is in vertical racks no more than 30 cm in width to give adequate support and stability. Sheets may be withdrawn with little risk of damage. Horizontal racking is not recommended for storing Perspex sheets as surface damage can occur from trapped grit when withdrawing sheets. To prevent deterioration to the masking film, all Perspex sheets must be stored indoors, preferably in a cool, well ventilated, dry room maintained at a reasonably constant temperature.

## 7.0 PREPARING FOR FABRICATION

The masking film can frequently be left in place during fabrication work and all marking-out drawn on the film. The film must be removed before thermoforming operations although in the case of Perspex XT extruded acrylic sheet the film may often be left in place provided sheets are only lightly formed and the film is in good condition. Scratches, cuts or other imperfections in the film will cause "mark-off" on the thermoformed article and it is therefore the customer's responsibility to decide whether the film can be left in place during thermoforming or should be removed.

## 7.1 Cleaning

Surfaces of items made from Perspex® from Lucite® should not generally require cleaning until after fabrication and before packaging. If however any surface decoration process is planned such as vacuum metallization or screen printing it is advisable to wash the sheet surfaces to be decorated with clean, fresh water using a chamois leather or soft cloth. This has the advantage of removing all traces of static charge from the sheet after removal of the film which might otherwise attract dust. For all general purpose cleaning operations, Perspex® should be washed simply with clean cold water to which a little detergent has been added. The use of any solvents such as methylated spirits, turpentine, white spirit or proprietary window cleaning products is neither necessary nor recommended.

## 8.0 MACHINING

The machining characteristics of Perspex from Lucite are similar to those of soft brass or hard aluminium, but there are two important differences:-

1. Perspex will soften if heated above 80°C. Considerable heat can be generated by machining, causing stress, so it is therefore very important that heat build-up is kept to a minimum. The use of coolants during machining is recommended to assist in lubrication, removing swarf and to maintain a cool stress-free machining temperature.
2. Perspex is a brittle material. It is therefore important that only light machining cuts are taken and feed rates are kept slow. Various coolants can be used including water and water/air mists, soluble oils and compressed air. Soluble oils must be oil-in-water emulsions and must not contain solvents which may cause stress cracking.

When machining, drilling or cutting Perspex, the heat build-up can generate stress in the final workpiece which can induce “stress-cracking”, a phenomenon common to many plastics materials when stressed. The risk of crazing can be reduced or eliminated by the simple process of heat annealing and it is strongly recommended that all machined or worked components made from Perspex are annealed. Please see page 24 for full details of the annealing process.

### 8.1 Cutting Tools

To achieve a good finish on Perspex from Lucite, all cutting tools must be kept sharp. Most hand tools designed for use with wood and soft metals are suitable for use with Perspex except laminate cutters, guillotines and blanking dies. If necessary, these tools can be used with Perspex provided the sheet is heated to at least 50°C. Most power tools can be used and HSS tools bits are suitable to achieve a good cut finish. For lengthy runs, tungsten carbide tipped blades and tool bits are recommended for long life. For accurate work, especially where a high degree of finish is required, diamond-tipped tools are particularly suitable for machining Perspex.

### 8.2 Sawing

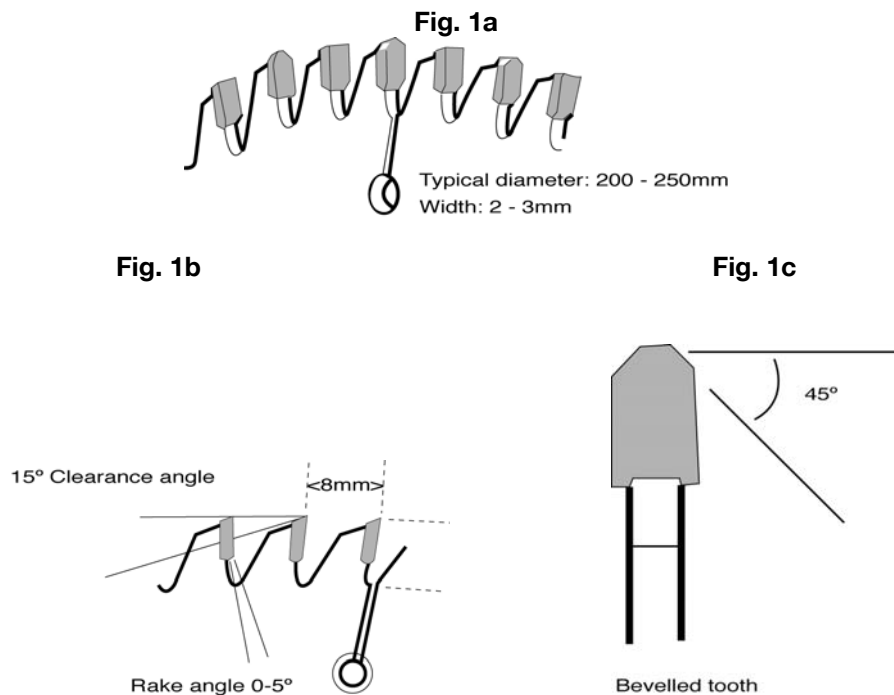
For small jobs, Perspex from Lucite may be cut with fine-toothed hand saws such as fret saws and hack saws. The work must be securely fixed and only light pressure applied. Powered saws with blades having alternative teeth bevelled, as for aluminium, are particularly recommended for sawing Perspex as are band saws, jig saws and fret saws. The recommended conditions for sawing Perspex are given in **Table 2**.

**Table 2** Conditions for sawing Perspex®

Saw Type	Optimum Blade Speed (approx)	Optimum Saw Pitch		Recommendation
		Sheet Thickness	Teeth/cm	
Bandsaw	1500 m/min	Up to 3 mm 3-13 mm Over 13 mm	6-8 4-5 1.5-2	Keep saw guides as close together as possible to prevent blade twisting
Circular saw (carbide tipped)	3000 m/min	All thicknesses	0.8-1.6	See Figure 1
Jig saw Fretsaw	Non critical	Up to 6 mm	5-6	Allow blade to stop before withdrawing from saw cut

**Figure 1** gives details of the recommended type of TCT circular saw blade suitable for cutting Perspex sheets.

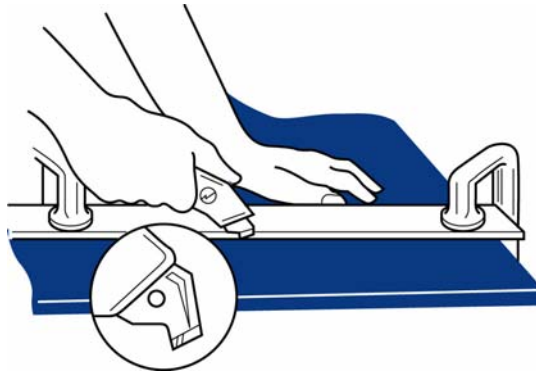
**Figure 1** A tungsten carbide tipped saw blade suitable for cutting Perspex



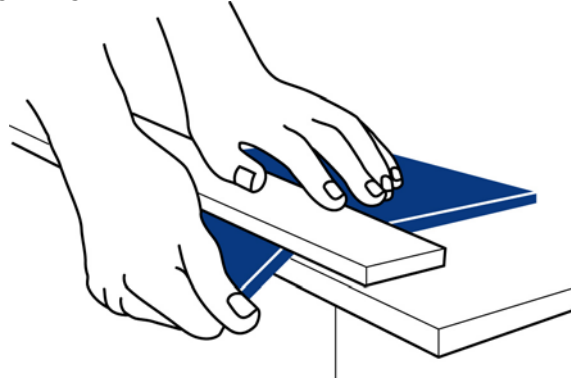
### 8.3 Scribe – Breaking

Perspex® from Lucite® up to 4 mm thick may be conveniently cut in a straight line by deeply scribing one surface several times with a sharp metal scribe, clamping the sheet with the scribed line uppermost and pressing sharply down over the edge of a bench. The technique, which is not applicable to Perspex® XT IM (extruded impact modified) sheet, requires some practice and is most suited to small pieces of thin extruded sheet. A suitable scribing tool is the STANLEY® knife laminate cutting blade No. 5194. See **Figures 2** and **2a** for details of scribe-breaking.

**Figure 2** Scribe-breaking Perspex®



**Figure 2a** Breaking along the scribeline

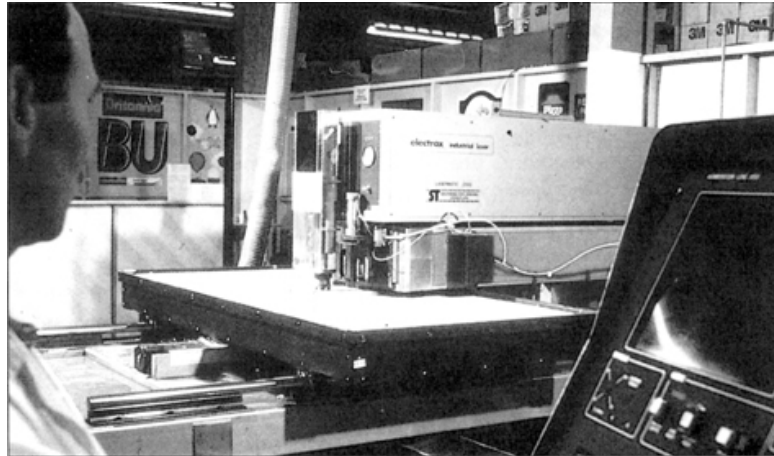


## 8.4 Laser Cutting

Perspex® from Lucite® may be laser cut (**see Figure 3**) and very complex and intricate shapes may be cut out using this type of equipment. Thicknesses up to 25 mm can be cut although some experimentation will be necessary to achieve the optimum quality of edge finish above 12 mm. Some stress can be generated around the edge of laser cut Perspex and it is important that the laser beam is accurately focussed. If cementing or surface decorating up to a laser cut edge it may be found necessary to carry out a short annealing cycle (see later) to reduce the risk of fine crazing along the edge. It may be found preferable to remove the top masking film to improve the edge polishing effect from the laser.

**NOTE:-** When laser cutting Perspex, as with all other materials, it is very important to provide adequate ventilation at the cutting head to remove any traces of unpleasant or even toxic combustion vapour. Expert advice should be sought from the machine manufacturers if in any doubt. Before laser cutting Perspex, please read the safety notes on flammability and combustion products on page 26.

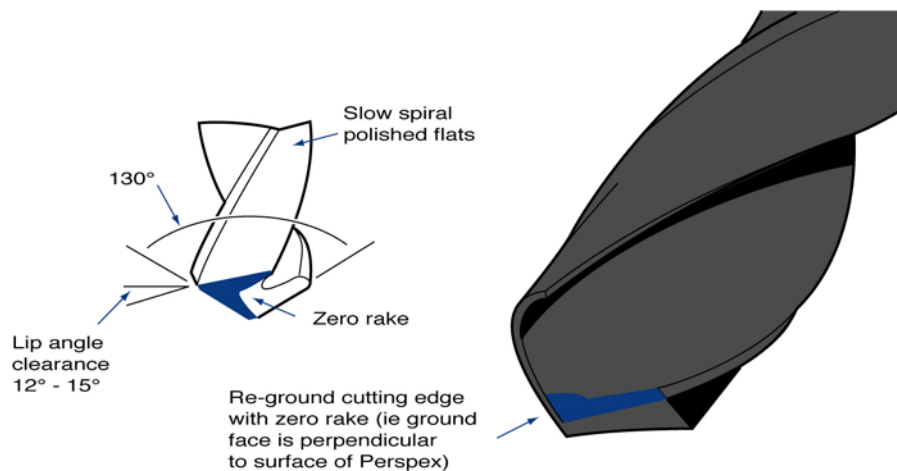
**Figure 3** Laser cutting machine



## 8.5 Drilling

Standard woodworking twist drills can be used for all normal drilling work with Perspex® from Lucite®. It is advisable to re-grind twist drills to give a zero rake; **Figure 4** demonstrates the preferred cutting angles.

**Figure 4** Standard drill (130°) with cutting edges re-ground for use with Perspex®



Wherever possible, the work should be supported by a back stop made from either scrap Perspex from Lucite or hard wood to prevent splintering the exit hole. Under no circumstances should a centre punch be used before drilling Perspex. A small pilot hole should be drilled first to locate the drill.

Coolants are strongly recommended for any deep drilling into Perspex and time must be allowed to remove swarf from the drill at regular intervals.

Hole saws may be used for larger holes greater than 12 mm diameter but when drilling large holes in thin extruded sheet, especially if it is not possible to support the work, "cone-cut" drills have been found to be particularly suitable.

## 8.6 Screwing and Tapping

Standard taps and dies may be used for cutting screw threads in Perspex® from Lucite® but wherever possible, coarse threads are preferred as they are less liable to damage. Lubricants are essential, water or soluble oil being preferred. Threads must not be overstressed and it is not advisable to thread Perspex® if frequent dismantling is likely. In such conditions, threaded metal inserts are recommended.

## 8.7 Turning

Perspex from Lucite can be turned on conventional metalworking lathes but it is important to keep the work cool by the use of coolants and ensuring that feed rates are slow. Any overheating of the work is likely to lead to localised distortions and a loss of tolerance. Crazeing may also occur some time after.

Correct grinding of the lathe tool is necessary. HSS tool bits are preferred, ground to zero rake at the top and 15 - 20° front rake. The fine grain texture of HSS tools ensures a better finish than TCT tools but all cutting surfaces must be kept very sharp.

Cutting speeds of 90 - 150 m/min are typical for turning Perspex but for a first class finish, speeds of 15 - 30 m/min are recommended.

Diamond fly-cutting is particularly recommended where a good polished finish is required after turning.

## 8.8 Spindle Moulding

A spindle moulder is a useful machine for the rapid machining of Perspex from Lucite. Cutters designed for woodworking are suitable, two-bladed cutters being preferred. Spindle moulding is carried out dry as swarf is easy to remove.

## 8.9 Engraving

Perspex from Lucite is easy to engrave using pantographs or CNC engraving machines. Laser engraving can also be carried out to give remarkable fine detail on Perspex. The use of coolants is generally unnecessary for mechanical engraving other than the use of a compressed air jet directed on to the cutting head to remove swarf and cool the cutter. Filling is best carried out using one of the usual setting waxes. Paints can be used but it is most important to use those paints intended for use with acrylic sheet and known to be compatible. When intending to engrave Perspex and fill with paint, especially for outdoor use, annealing of the engraved sections before filling is strongly recommended to prevent subsequent crazeing.

## 8.10 Routing

Routing is perhaps the most important machining operation used on Perspex from Lucite today. Fixed head, moving head or portable standard woodworking routers are suitable for Perspex using the same cutter speeds as for wood. Double edged cutters are preferred, ground and honed with a back clearance angle of about 12° or more.

Cutters	Spindle Speed
6 to 12 mm diameter or less	ca 24000 RPM
>12	ca 18000 RPM

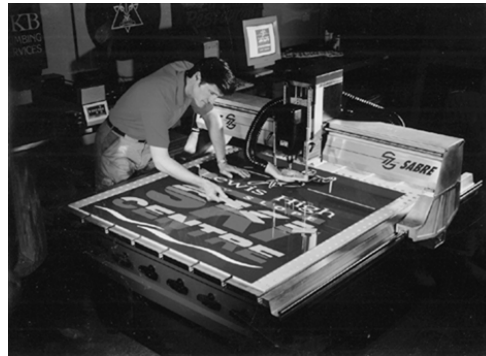
Routing is usually performed dry but provision must be made to clear all swarf from the work bench and keep the cutter cool. A compressed air jet directed at the workpiece usually performs this task.

HSS cutters give better results than TCT cutters although their life will be shorter. Regular sharpening is therefore necessary.

**Figure 5** The Pacer router supplied by Pacer Systems Limited



**Figure 6** The Gerber router supplied by Spandex plc



**Figure 7** Diamond polishing machine supplied by C. R. Clarke Ltd.



## 8.11 Finishing

Machined surfaces of Perspex® from Lucite® are usually matt unless diamond cutting tools are used. Machine marks are best removed by scraping with a sharp blade set at 90° or sanding and then the gloss finish restored by polishing.

### Sanding

Bench mounted or portable sanders may be used - as may belt sanders - to remove machine marks or saw cut marks from the edge of Perspex from Lucite.

Sanding should be carried out dry and only very light pressure applied to prevent softening or melting of the surfaces.

After any sanding operation it will be necessary to anneal the work if cementing or surface decoration is intended.

## Polishing

**Power buffing** with rotating calico mops is the traditional polishing technique for Perspex® from Lucite®. Edges must first be scraped or sanded to remove all machine marks then a mild abrasive buffing soap may be applied. Moderate speeds and only very light pressure is needed otherwise overheating will occur.

**Diamond polishing** can be used for straight edges and gives excellent results without the rounded edges often produced by buffing. See **Figure 7**. Diamond polishing produces very little stress in the surface.

**Flame polishing** is ideal for polishing thin edges of Perspex from Lucite, especially clear extruded sheet for point-of-sale items because it is fast and effective. A good routed or scraped edge is essential for flame polishing. Specialised equipment is available otherwise a small blowtorch type gas-air flame can be used. The technique requires some practice to achieve the desired level of skill. Only the slightest impingement of the hottest part of the flame is required rapidly passing the jet across the work. Great care must be taken not to ignite the surface and it should be noted that flame polishing can produce highly stressed edges. Annealing of the workpiece will be necessary if the flame polished edges are to be cemented or decorated.

**Flame polishing** can be difficult on certain heavily pigmented colours resulting in a matt finish or discolouration.

### NOTE:

**Before flame polishing, please read the safety notes on flammability on page 33.**

**Hand polishing** is suitable for the restoration of the original gloss finish after minor surface scratching. Deep scratches should first be removed using 600 grade waterproof abrasive paper applied wet with a light circular motion. To avoid optical distortions, the abraded area should be much larger than the damaged surface to “feather” the edges. Final polishing of the matt abraded area can be carried out using proprietary acrylic polishes available from your distributor of Perspex from Lucite sheet. Good quality metal polish intended for use on silver plate can be used provided the product has been tested and found to be compatible with Perspex®.

## 9.0 THERMOFORMING

### General

To thermoform Perspex from Lucite correctly it must be heated uniformly and cell cast sheet requires slightly more heating than extruded sheet. The optimum heating time and temperature will depend on the thickness of the sheet, the type of mould being used and the degree of stretching required.

Fundamental differences exist between the thermoforming of cast and extruded sheet and it is important to understand what these differences are before any work is started in order to achieve the best results. For example, Perspex XT (extruded) sheet has a lower melt strength than cast sheet, it softens more easily and can be stretched with very little force. For this reason it is more suitable for vacuum forming than Perspex cast sheet, which requires greater force and has lower elasticity. Extruded sheet if overheated will start to extend under its own weight if hung in a vertical heating oven and control of heating time and temperature are critical if oven heating is used.

The heating of extruded sheet on a horizontal oven shelf is not recommended because the hot sheet surface marks easily and can quickly stick to the shelf. Infra-red heated vacuum forming machines can overcome these difficulties and are the preferred option for thermoforming Perspex extruded sheet.

Perspex® cast sheet is more suited to thermoforming by mechanical press-forming where greater force can be applied by clamping and pressing.

## Heating

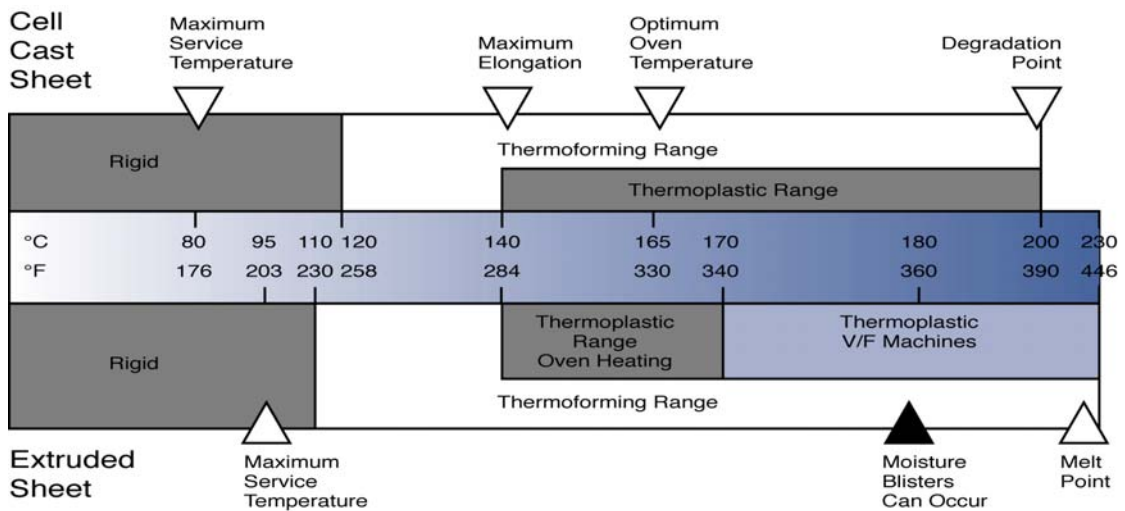
When Perspex® from Lucite® cast sheet is heated to 140 - 170°C it becomes flexible and rubber-like and can be formed into complex shapes by the application of force such as air pressure or mechanical press clamping. If held to that shape and cooled below 90°C it will retain the shape. If reheated, it will return to its original flat condition.

When Perspex XT (extruded) sheet is heated to this temperature range it behaves in a similar manner to cast sheet except that it is easier to deform, requiring less force and will actually flow rather than stretch. Consequently, mouldings made from extruded sheet will not return to the flat condition on re-heating.

**Figure 8** illustrates the effect of heating on both cast and extruded sheet and as a general rule, the preferred thermoforming temperature for cast sheet is 170°C and 155°C for extruded sheet.

**When heating impact modified grades of Perspex it will be noticed that the sheet becomes opaque at the shaping temperature. This is perfectly normal and the clarity will return when the shapings reach room temperature.**

**Figure 8** Heating Perspex – transition stages



Except when local bending, the entire area of Perspex from Lucite sheet should be uniformly heated and for cast sheet the best equipment for this is an air circulating oven with accurate temperature control. Both clear and coloured sheets may be laid on clean horizontal shelves in the oven but when optical quality is paramount, sheets should be hung vertically to avoid any surface damage or contamination during heating. Suitable hanging clamps can be devised to suspend the sheets along their longest dimension. Vertical hanging is also the recommended method for heating extruded sheets in an air circulating oven.

Figure 9 gives a guide to the relationship between temperature, force and extension during thermoforming.

Figure 9 Temperature versus pressure and extension for controlled oven heating

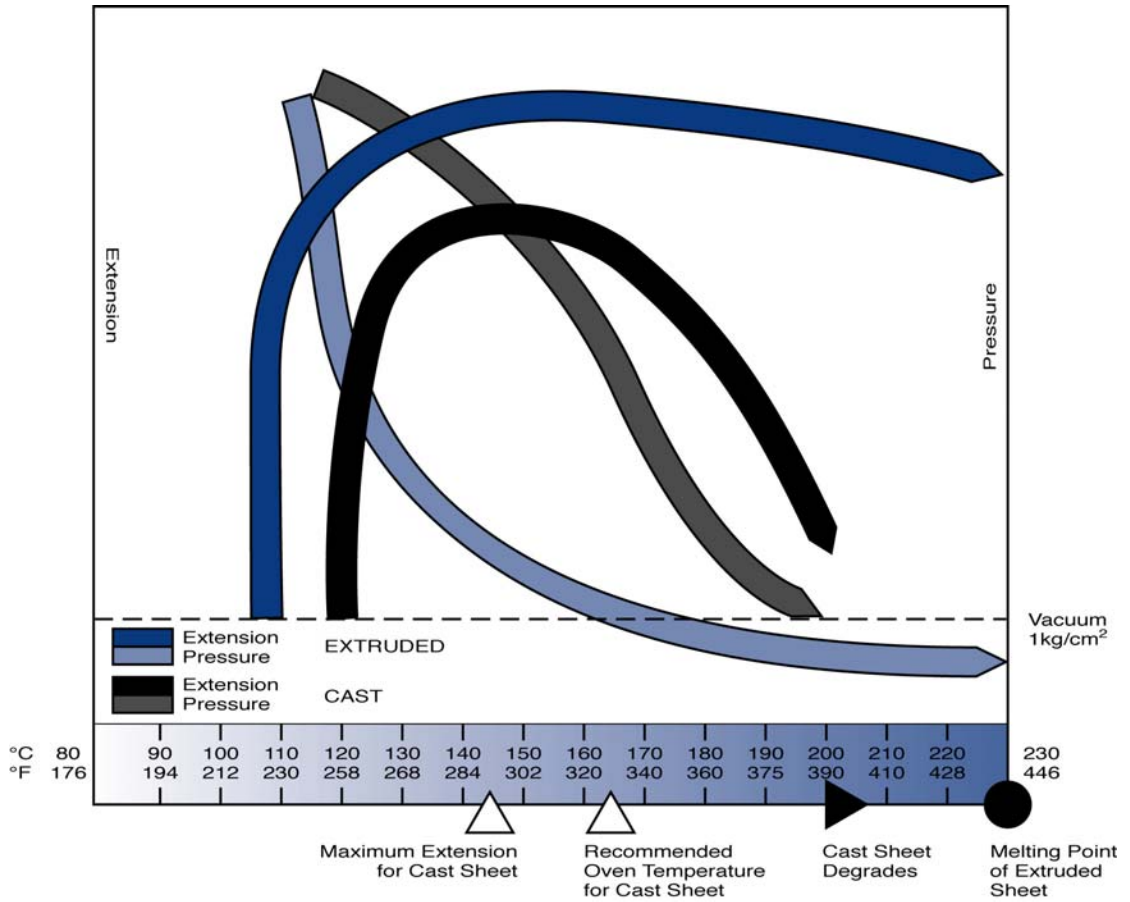
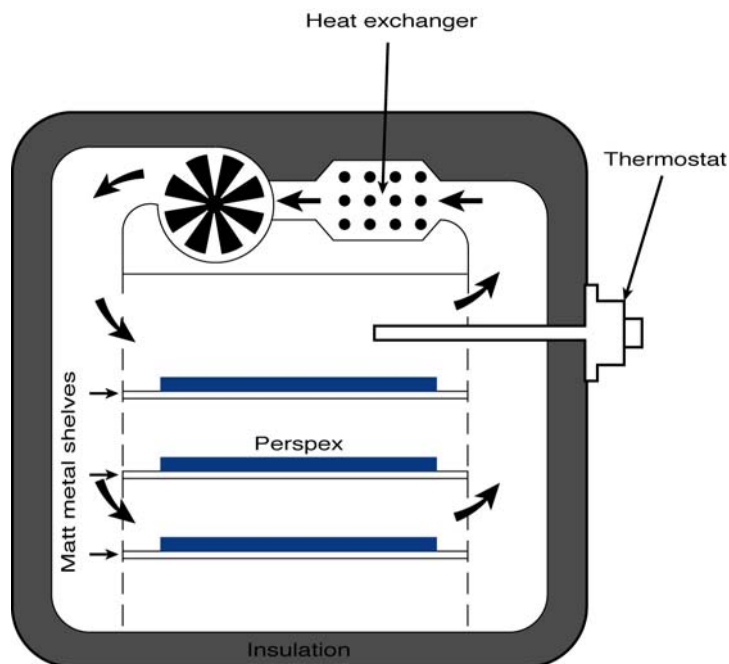


Figure 10 gives a diagrammatic description of a typical air circulating oven suitable for heating Perspex® from Lucite® sheets.

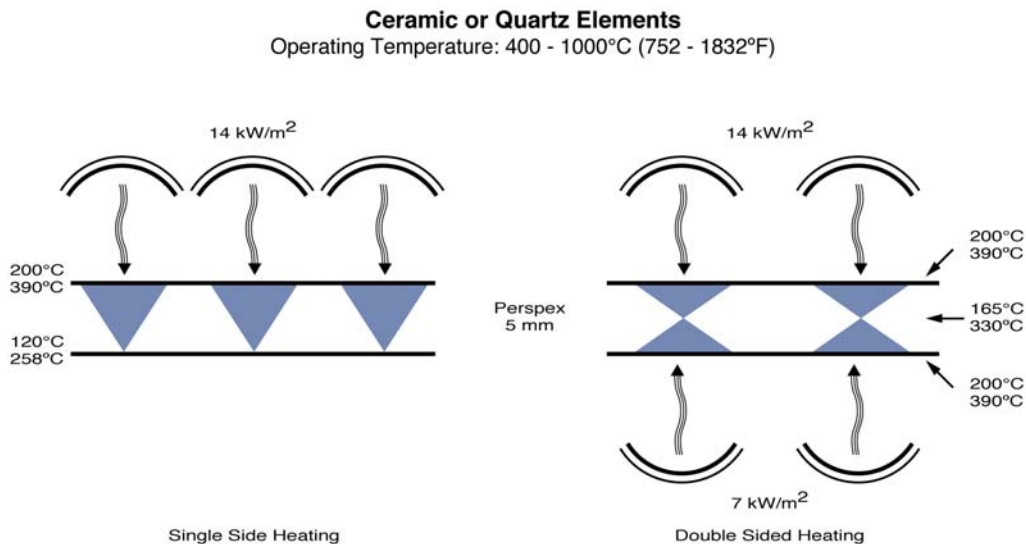
Figure 10 Air circulating oven



As an alternative to air oven heating, certain infra-red heaters can be used to heat Perspex® from Lucite® sheet, e.g. quartz and ceramic elements, but since these can heat the Perspex® surfaces very quickly, heaters and heated platens must be designed to give uniform heating under carefully controlled conditions to avoid overheating and degrading the sheet.

Figure 11 gives details of the heating of Perspex using typical infra-red heaters.

Figure 11 Infra-red heating of Perspex



When using infra-red heaters the sheet should be heated simultaneously on both sides, i.e. with the use of double-sided heater platens.

**SAFETY NOTE**

Infra-red heaters as used on vacuum forming machines can raise the temperature of the sheet very quickly and overheating is possible. If the surface temperature of Perspex from Lucite exceeds 200°C, degradation will occur leading to decomposition and the evolution of flammable decomposition gases. Initial indications of this for cast sheet are the appearance of blisters on the surface followed by a crackling sound as the sheet begins to decompose.

If blisters or bubbles appear in extruded sheet without any indication of decomposition it is more likely that this is due to absorbed moisture, requiring an overnight drying cycle at 90 - 95°C.

**Shrinkage**

The production processes for cast and extruded Perspex from Lucite sheets differ fundamentally and both materials will exhibit some shrinkage when heated to thermoforming temperature. When cast sheet is heated for example it will shrink such that on cooling again it will be approximately 2% smaller in both length and breadth with a perceptible increase in thickness. No further shrinkage will then take place on reheating but this initial shrinkage must be taken into account when cutting the sheet into blanks prior to thermoforming.

When extruded sheet is freely heated it will exhibit rather more shrinkage in the direction of extrusion and very little across the direction of extrusion. It is difficult to give precise figures for shrinkage of extruded sheet because this will depend on the thickness and the heating time. As a general rule, 2 mm sheet will shrink slightly more than 5 mm sheet when freely heated but typically no more than 5%.

When sheets are clamped cold in a frame prior to heating the shrinkage is restrained and no allowance for shrinkage should usually be necessary.

## Cooling

After thermoforming, Perspex® from Lucite® cast sheet should be kept on the mould until the temperature has reached about 60°C. Uniformity of cooling is important to prevent warpage and stress but mouldings should not be left on the mould too long otherwise they may contract tightly on to the mould and damage when lifted off.

Perspex® XT can be lifted off the mould at slightly higher temperatures, eg 70 - 80°C and to prevent warping of long, shallow components, thermoformings can be placed in cooling jigs on a bench, counterbowed if necessary, until room temperature is reached.

## Thermoforming of colours

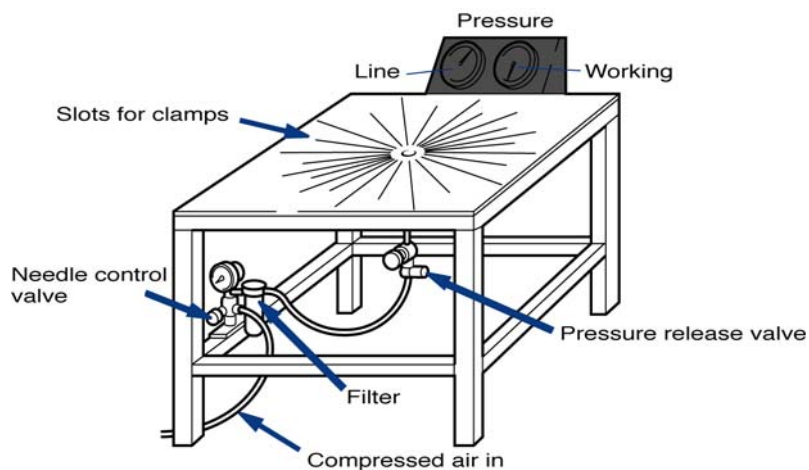
Certain Perspex from Lucite colours can change slightly during the heating process, especially if the sheet is overheated. It is always important to ensure that the first surface is always the showface as the second surface can be slightly duller after heating. It is also important to note that as coloured sheet is stretched during thermoforming there will be an inevitable thinning of the sheet in those areas which can give rise to a reduction in opacity.

For Perspex® cast sheet colours, the showface is always that surface covered by the printed masking film.

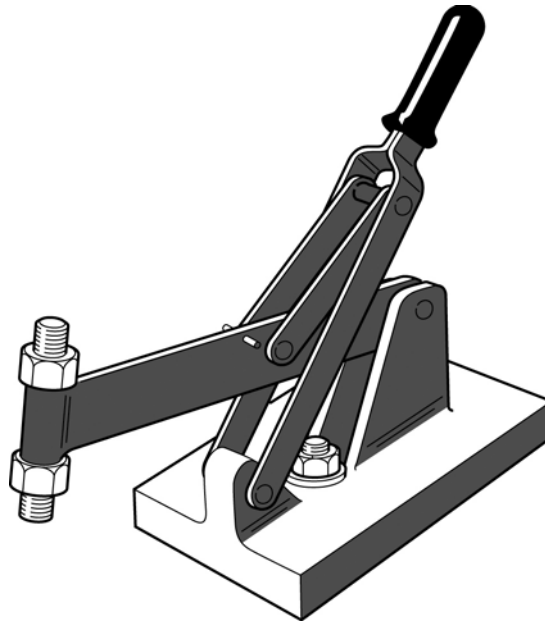
## 9.1 METHODS OF THERMOFORMING

Perspex from Lucite can be thermoformed by a number of simple techniques, the most suitable of which will depend on the amount of stretch required to achieve the desired result. For blowing domes and similar shapes a blowing table will be needed fitted with toggle clamps and using steels rings to clamp the hot sheet down. **Figures 12 and 13** illustrate typical basic designs.

Figure 12 Typical blowing table

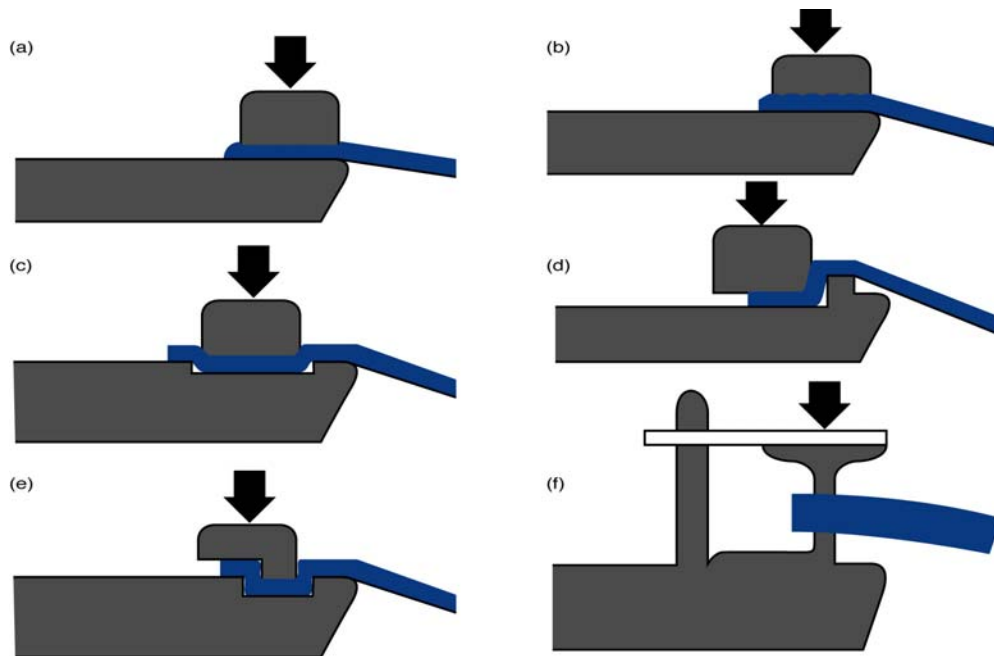


**Figure 13** Toggle clamp



**Figure 14** illustrates typical clamping designs to hold the hot sheet under the blowing ring using toggle clamps.

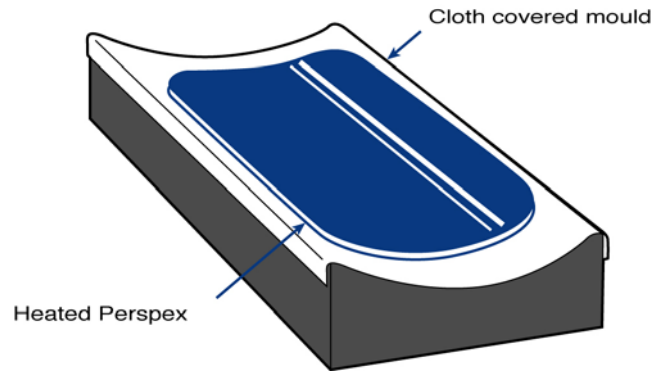
**Figure 14** Methods of clamping Perspex® from Lucite® for thermoforming



## Single curvature thermoforming

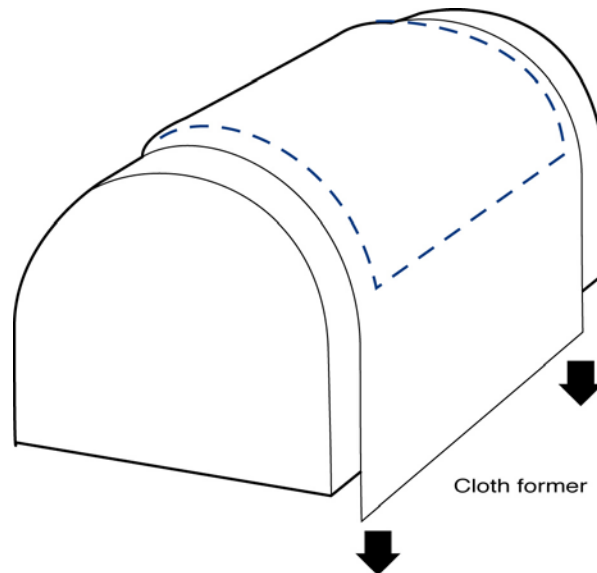
Because there is virtually no stretching, single curvature thermoforming requires very little force. **Figure 15** shows a typical mould for making motor cycle windscreens. The hot Perspex from Lucite is laid on to the mould covered with several layers of mould cloth to prevent surface marking. The sheet then takes up the shape of the curvature.

**Figure 15** Single curvature thermoforming



Drape forming is another single curvature thermoforming technique. Slightly more force is applied by draping the hot sheet over a mandrel mould and holding it there with several layers of soft mould cloth until it has cooled. **See Figure 16.**

**Figure 16** Drape forming

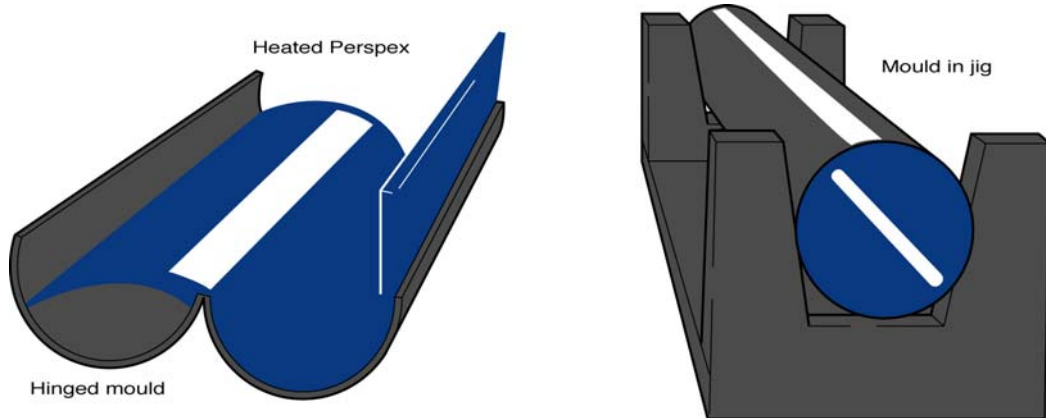


## Tubes

Tubes can be made by laying the hot Perspex<sup>®</sup> from Lucite<sup>®</sup> sheet into a split cylindrical mould and dropping this into a jig to keep it tight. Allowance has to be made for thermal contraction and some experimentation may be required to obtain the correct blank size. Once shaped, the split line may be cemented.

**Figure 17** illustrates the method and tooling. The technique is useful for producing large diameter tubes for display models for example which cannot be conveniently made by extrusion or casting.

**Figure 17** Making a tube from Perspex® from Lucite®



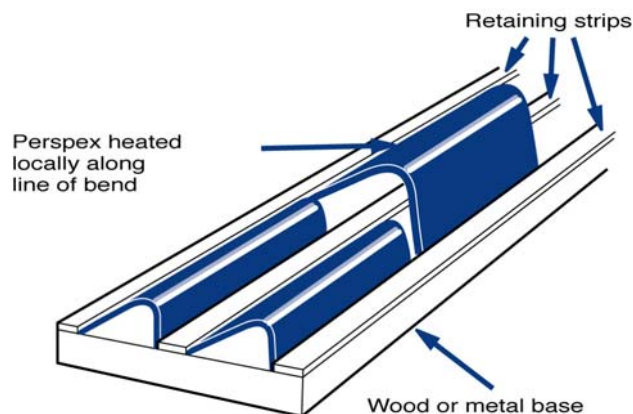
## Local bending

Local bending - sometimes referred to as line bending - is a very important technique for producing display items, point-of-sale and many more components from Perspex from Lucite, including boxes, shelf racks, light fittings, food trays, etc.

Perspex from Lucite sheets are softened along a narrow line by a strip heater, usually a hot wire. When the shaping temperature is reached the sheet is bent and clamped or placed in a jig to cool. Suitable heaters for local bending work include nichrome wire and electrical heating tapes, depending on the radius of curvature needed and thickness of sheet used. For sheets thicker than 5 mm double sided heating is recommended and although the equipment can be built in the workshop, excellent commercial machines are readily available. **Figure 18** shows a typical cooling jig for local bending.

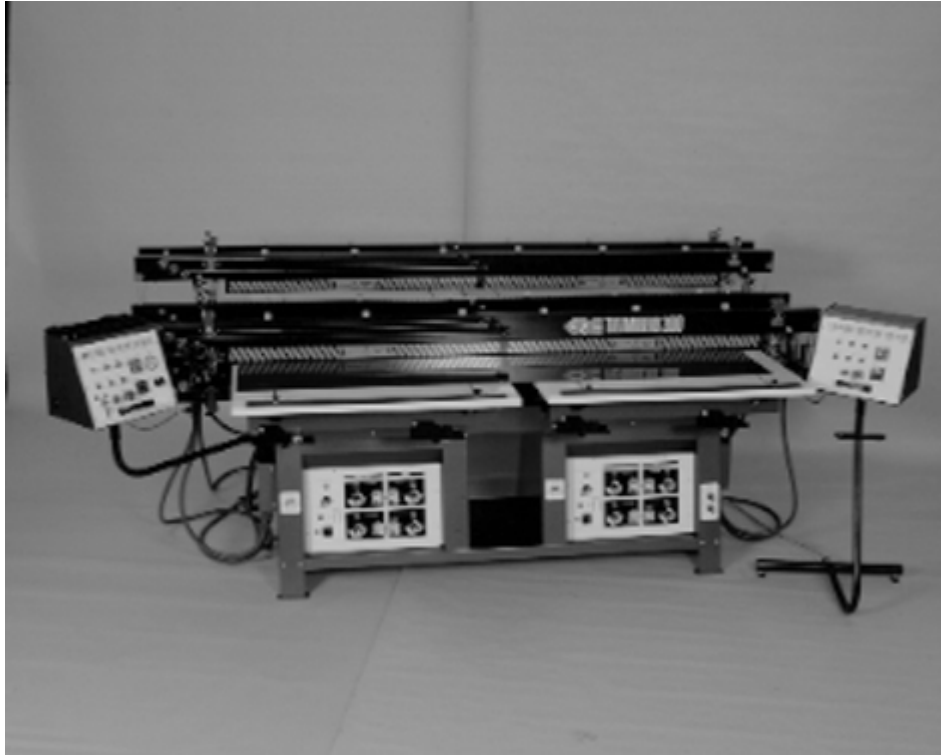
For local bending of thick cast sheet where a sharp radius is required, it can sometimes be helpful to machine a "V" groove along the inside face to approximately half the sheet depth. This has the effect of removing material and making it easier to bend into a sharp angle but at the risk of producing a weaker edge.

**Figure 18** Cooling jig for locally bent Perspex®



**Figure 19** shows a popular line bending machine supplied by C.R. Clarke Limited. For a sharp bend, the width of the heating zone should be about 4 to 6 times the thickness of the sheet. When local bending of long shallow sections, some warpage will be noticed along the line of the bend. This is always possible with local bending and is very difficult to avoid. If warpage is totally unacceptable the only alternatives are full sheet thermoforming or cementing.

**Figure 19** Line bending machine



To reduce warpage it is advisable to produce as near to a right angled bend as can be accepted since this will provide extra stiffness to the panel. Distortion tends to be greater the more shallow the angle of bend.

**NOTE:**

1) Local heating of Perspex<sup>®</sup> from Lucite<sup>®</sup>, especially line bending, induces localised stresses in the line bend due to shrinkage along the heated section. Stress cracking can occur - especially with extruded sheet - in the presence of solvents in cements, inks or spray paints. To minimise the risk of crazing, all locally bent components should be annealed after bending.

**When making sun bed covers by local bending Perspex<sup>®</sup> 0X02 it is ESSENTIAL to follow the recommendation on annealing because many disinfectant solutions commonly used in salons contain alcohols and serious crazing can occur if covers are not annealed after local bending. See page 24 for full details of the annealing procedure.**

2) Metal contact heaters may not be suitable for use with Perspex XT as they may stick to the surface of the sheet and cause marks.

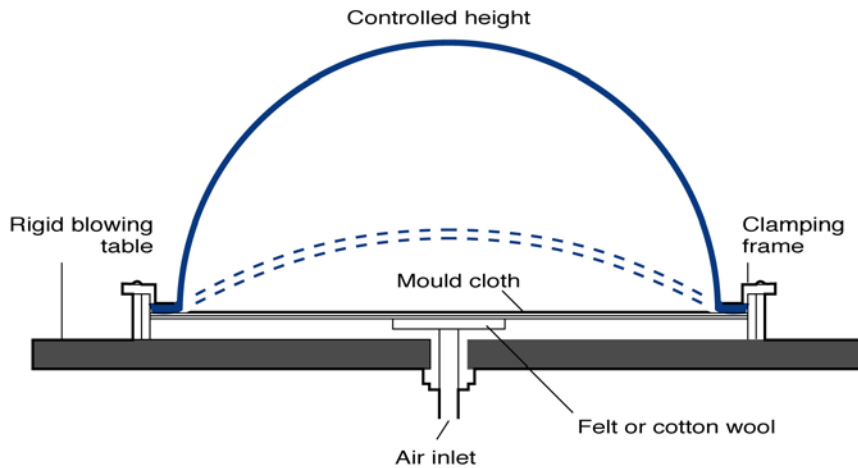
## 9.2 DOUBLE-CURVATURE THERMOFORMING

This technique involves clamping the hot sheet around its edges and forming a three dimensional structure by various means, e.g. air pressure, press forming, etc.

### Free blowing by air pressure without a mould.

The hot sheet is taken from the oven and laid on a blowing table, clamped securely and air pressure injected until the dome achieves the desired shape and height, **Figure 20**. Low pressures are adequate although the larger the dome the lower the pressure required. Thick sheet will require more air pressure than thin sheet. More care is needed when using extruded sheet and it is preferable to use a carrier plate to heat and transport the sheet to the blowing table to avoid heat loss which may cause mould chill marks. The carrier plate should therefore be covered with several layers of mould cloth and drilled in the centre to accept air injection. It can also be sometimes beneficial to pre-heat the air to avoid chill marks on the extruded sheet by applying tape heaters to the air line.

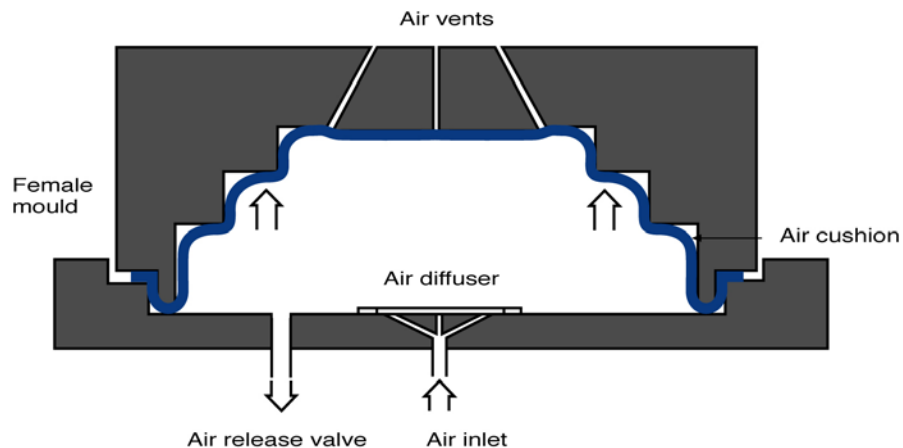
**Figure 20** Free blowing technique using air pressure and a blowing table



### Forming using a mould and air pressure

Perspex<sup>®</sup> from Lucite<sup>®</sup> cast sheet can be pressure formed using moulds and air pressure to achieve good definition. Moulds may be made from metal or resin bonded materials and even hard woods but it is very important to ensure that the moulds will be able to withstand the high air pressures. **Figure 21** illustrates a typical design of pressure mould: note air vents to release trapped air.

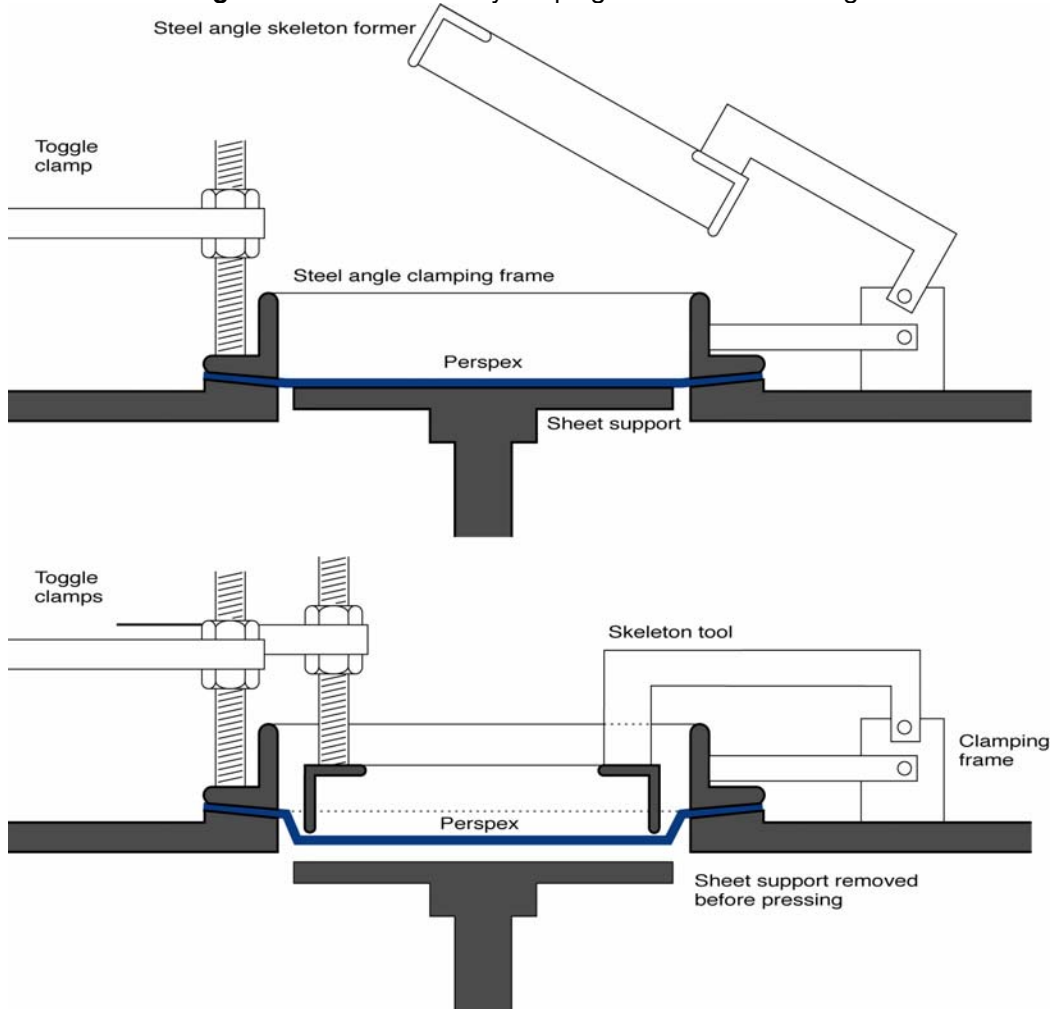
**Figure 21** High pressure moulding using a female mould



## Press forming using clamps and tools

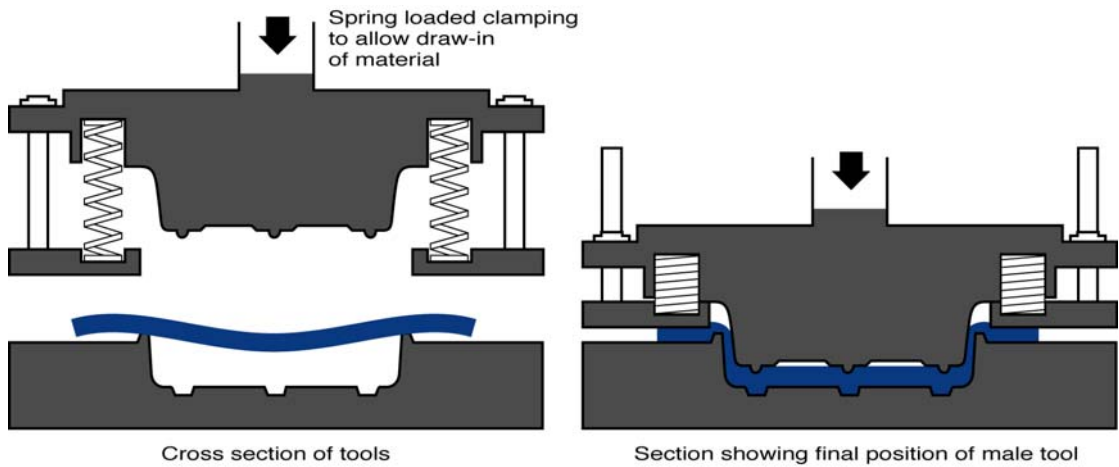
The majority of shaping processes for Perspex® from Lucite® involve the use of clamps and tools often of the simplest design. For many articles where the optimum clarity must be retained the use of skeleton tooling is to be preferred where the clamped hot sheet is pressed into shape using thin metal formers which only touch the perimeter areas, thereby preserving the original high gloss finish of the sheet. (See Figures 22a and 22b)

Figures 22a and 22b Tray shaping with skeleton tooling



**Figures 23 and 24** illustrate more complex methods of shaping Perspex® from Lucite® using presses equipped with pneumatic rams.

**Figure 23** Press forming using matched male and female moulds



### 9.3 VACUUM FORMING

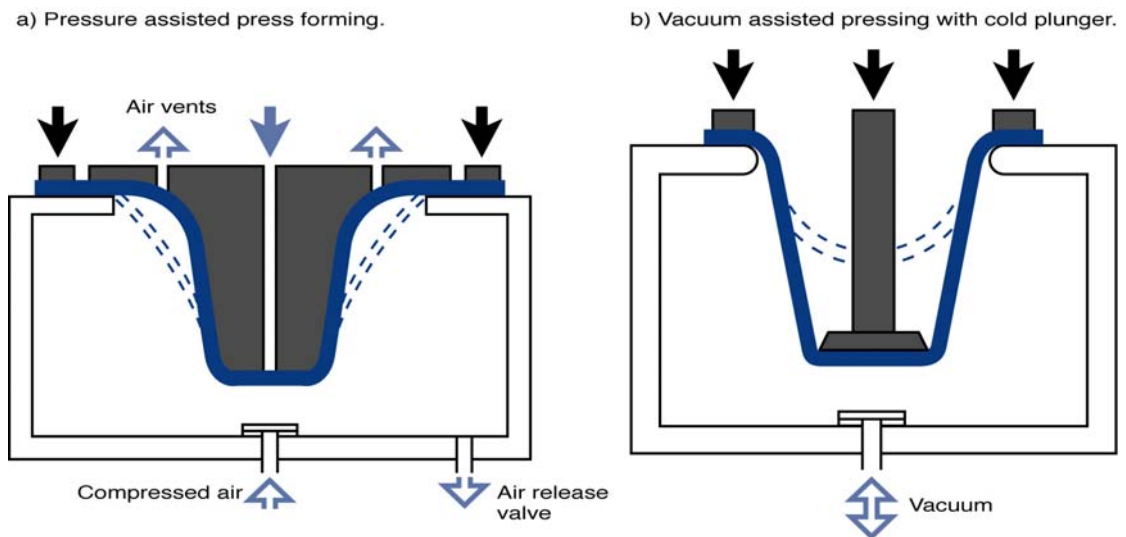
Vacuum forming is a well established process for shaping articles from polymer sheet materials and many commercial computer-controlled vacuum forming machines equipped with infra-red heating platens are available for high speed production work. Perspex® from Lucite® extruded sheet is ideally suited to the vacuum forming process because, due to its lower melt strength, it can be drawn by the relatively low vacuum forces, has high extensibility and therefore high definition within the mould.

Perspex® cast sheet requires higher shaping forces and is therefore less suitable for the low pressure vacuum forming process - unless the shapes are quite large and simple in design such as a domestic bath.

#### Moulds

For long production runs and high quality mould detail cast aluminium moulds cored for water cooling are recommended. A smooth matt finish is preferred and all dust must be kept clear of mould surfaces to prevent dust marks, especially when moulding clear sheet. Mould temperatures should be maintained at between 80-95°C.

**Figure 24** Press forming using air and/or vacuum



## Heating

Double-sided heating is recommended for all Perspex from Lucite vacuum forming above 2 mm thickness. It is difficult to give precise recommendations on heating times and conditions because these vary according to the machine design and the machine supplier may be able to give some information. Generally speaking, top heaters are typically set for a heat output of 20 kW/m<sup>2</sup> and lower heaters for 8 kW/m<sup>2</sup>. Starting at this level the sheet should be heated carefully and examined regularly until it is ready for shaping. Some trial and error will be needed to reach this stage but it is particularly important not to overheat the sheet and allow it to sag on to the hot lower heater since damage could occur to the machine with the possible risk of fire. The use of "levelling" is advisable by injecting air into the box cavity so supporting the hot sheet during the final heating stages.

Extruded sheets can absorb moisture which can cause blistering when vacuum forming. If moisture blisters occur when vacuum forming Perspex<sup>®</sup> XT the sheet should be dried before use, preferably with the masking film removed. At least 24 hours drying time may be required at 90 - 95°C.

## Cooling

Mouldings should be removed as soon as possible while still quite hot otherwise they may shrink on to the mould and be difficult to remove. If removed too hot they may distort. The use of cooling jigs may be beneficial where fast cycle times are required without the risk of distortion but once again the ideal conditions are best found by experiment.

## 10.0 CEMENTING

All grades of Perspex<sup>®</sup> from Lucite<sup>®</sup> can be bonded using acrylic cements. A range of Tensol<sup>®</sup> cements and Tensol adhesives is produced and supplied by Bostik<sup>®</sup> Ltd, to whom all enquiries should be directed.

The correct selection of adhesive is vital in order to produce bonds with good strength, durability and optical clarity.

### Lamination/Face to Face Bonding

Two sheets of Perspex from Lucite may be laminated together using the solvent-free clear adhesive Tensol 70 from the Bostik range. Tensol 70, applied with the appropriate EVO-PLAS<sup>®</sup> application bottle, will produce a bond which is durable in external applications, has excellent optical clarity and good mechanical strength. For laminating Perspex<sup>®</sup> to polycarbonate, or for encapsulating items speak directly to Bostik.

### Edge Bonding

Solvent welding is the quickest and easiest way of forming edge bonds. The best results can be easily and safely achieved when EXTRU-FIX/Tensol 12 are applied using an EVO-PLAS application bottle. Features of this system - which is intended for **indoor** applications - include good resistance to stress crazing, even on line-bent sections, and high clarity, bubble-free bonds. Filled systems such as Tensol 12 offer slightly better gap filling properties.

For external applications, a highly durable adhesive such as Tensol 70 is required.

When cementing Perspex XT (extruded) items, great care must be taken when using Tensol 12 or Tensol 70, in order to avoid stress crazing. This is most critical on line bent joints, where EXTRU-FIX<sup>®</sup> may be more appropriate.

## **Bonding to other Substrates** (metal, wood, glass etc.)

The easiest way to bond Perspex from Lucite to other substrates is by using a cyanoacrylate adhesive, Bostik 7452 is suggested. As well as being useful for bonding small areas of Perspex to Perspex, this system is also suitable for attaching fittings to Perspex.

Where there are high mechanical strength requirements, a toughened acrylic adhesive, such as EVO-tech® TA 431, is to be preferred.

## **Sealing**

Joints in Perspex® from Lucite® and a variety of other materials can be effectively sealed with a suitable, acrylic compatible silicone sealant or MS polymer. In order to avoid stress-crazing, the sealant needs to be neutral cure. A low modulus type, such as Bondflex® Low Modulus Silicone Sealant will best accommodate any movement in/between the components.

The Bostik range of adhesives, Cleaning solvents, MIRROR ADHESIVE and ANTI-STATIC CLEANER is available from most Perspex from Lucite stockists and distributors. Alternatively please contact Bostik directly (on +44 116 268 9254) - see Appendix for full address.

Before cementing, the user should study the Safety Data Sheets and ensure that the adhesive is suitable for the intended application.

## **11.0 PRINTING, PAINTING AND SURFACE DECORATION**

Perspex from Lucite can be readily screen printed, painted or hot-foil stamped. Paints and screen inks formulated for use on acrylic sheet must be used and it is strongly recommended that the sheet surfaces are washed before decorating to obtain maximum service life outdoors. Screen inks are available for thermoforming and it is important to ensure that any screen inks or paints applied to Perspex have adequate UV stability.

For further details of the surface decoration of Perspex, please see **261, Corporate Imaging**.

## **12.0 STRESS IN ACRYLIC SHEET**

Stress is a phenomenon which can affect many materials including acrylic sheet. It is produced by the application of force and, if excessive, can result in total mechanical failure. Long before these limits are reached with acrylic sheet the appearance of fine crazing or stresscracking can occur over time which, at best, is unsightly and at worst, can reduce the mechanical properties of the material.

Stress may be generated by thermoforming at too low a temperature, by the application of mechanical force or by the generation of heat during fabrication, e.g. machining and drilling. Crazing is induced by the release of stress, especially inherent stress, brought on by exposure to chemical solvents (environmental stress cracking), cements, screen printing ink or exposure to high energy radiation.

It is therefore important to ensure that only the minimum stress is induced in acrylic sheet when fabricating or thermoforming and that component parts are designed to prevent excessive mechanical loads being applied during service. Extruded acrylic sheet has a lower stress level tolerance than cast sheet and particular attention must be given to design parameters when using this material.

Inherent stress, (i.e. moulded-in stress) can usually be eliminated after moulding or fabrication by an annealing process. This is a gentle heat conditioning process that

allows the release of stress without crazing to produce a stress-free component. Annealing should be undertaken whenever fabricated parts are to be cemented or screen printed, especially when using extruded acrylic sheet.

## 12.1 ANNEALING

The recommended annealing process for cast Perspex® from Lucite® is as follows:

1. Place the components in an air circulating oven at room temperature.
2. Raise the oven temperature at a rate not exceeding 18°C per hour.
3. When the annealing temperature of 90°C is reached, maintain the temperature for:
  - a) 1 hour for up to 3 mm thickness.
  - b) 2 hours for up to 6 mm
  - c) 4 hours for up to 12 mm
  - d) 6 hours for up to 20 mm
4. Cool to room temperature at a rate not greater than 12°C per hour.

For thermoformed components the annealing temperature should be reduced to within the range of 70 - 85°C.

It is advisable to anneal all extruded sheet components before cementing, painting or screen printing.

A rapid annealing cycle which is reliable, especially for thin sheets, is to pre-heat the oven to 80°C, anneal for one hour, then remove the parts from the oven and allow cooling to room temperature.

## 12.2 NORMALISING

Perspex from Lucite cell cast acrylic sheet contains stresses introduced during the casting process and under normal circumstances these have no effect on the behaviour of the final article. If however components are being machined to very close tolerances it is advisable to remove these casting stresses by the process called normalising. By heating Perspex® above its glass transition temperature, the stresses are relaxed giving rise to a uniform shrinkage of approximately 2%. Normalised Perspex is therefore said to be fully stress-relieved and fully shrunk. The normalising process consists of a closely controlled temperature and time cycle depending on the sheet thickness. The sheet to be normalised is heated to 140°C in an air circulating oven and held there until it has been heated uniformly. It is then allowed to cool down slowly to avoid the reintroduction of thermal stresses.

Cooling rate from between 105 - 110°C to room temperature: not greater than 4°C/hour. Minimum cooling time 21 hrs. Maximum allowable differential between material and ambient temperature at time of removal from oven is 7°C.

The treatment conditions, especially for thick sheet and block, are quite critical and **Table 3** gives typical normalising cycles for cast Perspex.

**Table 3** Typical normalising cycles for cast Perspex® sheet & block

THICKNESS (mm)	CYCLE HEATING TO		HOLDING AT 140° C		COOLING TO 105 – 110° C		HOLDING AT 105-110°C	
	Hour	Min.	Hour	Min.	Hour.	Min.	Hour	Min.
3		30		50		30		30
4		30	1	30		30		50
5		30	1	30		30		50
6		30	1	40		30		50
8	1	00	2	15	1	00	1	30
10	1	00	3	00	1	00	1	30
12	1	00	3	45	1	00	1	50
13	1	00	3	45	1	00	1	50
15	1	00	4	15	2	00	2	00
20	1	30	5	30	3	30	3	00
25	1	39	7	00	3	30	3	30
30	1	45	8	30	4	45	4	00
35	2	00	9	45	5	00	5	00
40	2	30	11	15	5	30	5	45
45	2	30	12	30	6	30	6	30
50	3	00	14	00	7	00	7	00
55	3	00	15	30	7	00	7	45
60	3	30	16	45	8	30	8	30

## NOTES

- 1) Assuming room temperature 20°C.
- 2) Take the actual sheet thickness.
- 3) For sheet thicknesses significantly different to those above either calculate the appropriate cycle, or use that given for the next larger thickness.

## 13.0 SAFETY

### Handling and machining

Perspex® from Lucite® is a hard material. Sharp edges can cause cuts and chips can damage eyes. Appropriate personal protective equipment should be worn, as sharp edges can cause cuts, and chips can cause eye damage.

### Thermoforming

When using presses or rams for thermoforming it is imperative that adequate safety devices are in place to prevent hands being trapped during the operation of the press. These should include guards and safety interlocks, and all safety fixtures must be maintained in good working order.

When using pressure forming it must be remembered that the sheet may burst if too much pressure is applied. To reduce the risk of bursting, the following precautions should be considered:

1. The air supply to the machine must be provided with a pressure relief valve or reducing valve set to limit the pressure to the minimum required to form Perspex from Lucite at its correct shaping temperature.
2. Safety shields should be installed on the machine to protect operators from accidental bursts.

3. Safety equipment must be maintained and inspected at regular intervals to ensure safe working order.

Ovens should be fitted with fail-safe thermal cut-out switches to prevent the risk of overheating.

### **Flammability**

All Perspex<sup>®</sup> from Lucite<sup>®</sup> grades are combustible and if ignited will continue to burn. Little smoke is evolved when Perspex<sup>®</sup> burns.

The combustion products when Perspex burns vary with temperature and the amount of oxygen present. A full study of the combustion gases evolved under widely different conditions has been made (see Reference). The conclusions were that carbon monoxide was always the major toxic gas present with carbon dioxide, water and methyl methacrylate.

### **Reference**

A study of DIN 53436 and NBS (Potts' PA) as fire models for the assessment of the toxicity of combustion products of plastics. British Plastics Federation Publication 314/1 April 1987.

## **14.0 CHEMICAL RESISTANCE**

Perspex from Lucite has very good resistance to attack by water, alkalis, aqueous inorganic salt solutions and most common dilute acids. It is difficult to generalise about the effects of organic materials on Perspex, some liquids have no effect at all, some cause swelling, crazing or weakening and some dissolve it completely.

**Table 4** gives an indication of the chemical resistance of Perspex cast clear as judged by the visual appearance of samples of dimensions approximately 100 x 12 x 6 mm immersed in typical solutions or liquids at 20°C.

**Table 4** The chemical resistance of Perspex® from Lucite® cast clear at 20°C  
The following symbols have been used in the table:-

S = Satisfactory (no apparent effect apart from possible staining)

A = Some attack evident (swelling or slight crazing)

U = Unsatisfactory (the sample has dissolved, swollen, decomposed, etc.).

CHEMICAL	CONCENTRATION	RESISTANCE	EXPOSURE TIME	NOTES
Acetic acid	10%	S	5 years	
	100%	U	1 day	Badly swollen
	Glacial	U	3 days	Dissolved
Acetone	100%	U	1 day	Dissolved
Alcohols, n-butyl		U	1 year	Crazing and disintegration
	Ethyl	10%	A	Slight attack
	50%	A	1 year	Slight attack
	100%	U	1 year	Slight swelling and softening
Isopropyl	10%	A	1 year	Crazing
	50%	A	1 year	Crazing
	100%	A	1 year	Attacked
Methyl	10%	A	1 year	Slight attack
	50%	A	168 days	Swollen
	100%	U	168 days	Swollen: weight increase
Ammonia	0.880 sol.	S	1 year	
Amyl acetate		U	28 days	Dissolved
Aniline		U	7 days	Dissolved
Aviation fuel	100-octane	A	168 days	Slight crazing
Benzaldehyde		U	7 days	Dissolved
Benzene		U	10 days	Dissolved
Calcium chloride	Saturated sol.	S	3 days	Slight attack
Carbon tetrachloride		U	84 days	Dissolving
Chloroform		U	1 day	Dissolved
Chlorine	2% in water	A	5 years	Surface crazing and attack
Chromic acid	10%	S	5 years	Stained
	Saturated sol.	U	1 year	Dissolving
Citric acid	Saturated sol.	S	5 years	
Dibutyl phthalate		A	2 years	Surface crazed
Diethyl phthalate		A	2 years	Slight attack
Dibutyl sebacate		A	2 years	Slight attack
Diethyl ether		U	168 days	Swollen & Soft
Ethylene glycol		S	5 years	
Ethylene dichloride		U	1 day	Dissolved
Ethyl acetate		U	3 days	Dissolved
Epichlorhydrin		U	1 day	Dissolved
Formaldehyde	40%	S	5 years	
Formic acid	10%	S	5 years	
	90%	U	7 days	

# Workshop Handbook

CHEMICAL	CONCENTRATION	RESISTANCE	EXPOSURE TIME	NOTES
Glycerol (glycerine)		S	5 years	
Hexane		S	168 days	Slight crazing
Hydrochloric acid	10%	S	168 days	Slight crazing
	Conc.	S	168 days	Slight crazing
Hydrocyanic acid		U	1 day	Dissolved
Hydrofluoric acid	Conc.	U	1 day	Swollen & Soft
Hydrogen peroxide	10 vol.	S	1 year	
	90%	U		
Mercury		S	2 years	
Methylene chloride (dichloromethane)		U	1 day	Dissolved
Methyl salicylate		U	7 days	Dissolved
Nitric acid	10%	S	1 year	
	Conc.	U	1 day	Swollen
Oils - transformer		S	5 years	Staining
- diesel		S	1 year	Hazing
- olive		S	5 years	Slight crazing
-paraffin (medicinal)		S	5 years	
- silicones		A	1 year	Swollen
Oxalic acid	Saturated sol.	S	5 years	Severe crazing
Perchloroethylene		U	5 years	Severe crazing
Phenol	Saturated sol.	U	7 days	Dissolved
Phosphoric acid	10%	S	5 years	
	Conc.	U	7 days	Severe crazing
Potassium dichromate	10%	S	5 years	Slight staining
Potassium hydrozide	Saturated sol.	S	168 days	
Potassium permanganate	N/10 sol.	S	5 years	Severe staining
Sodium carbonate	Saturated sol.	S	5 years	
Sodium chlorate	Saturated sol.	S	5 years	
Sodium hydroxide	Saturated sol.	S	5 years	
Sodium hypochlorite	10% chlorine sol.	S	5 years	
Sulphoric acid	10%	S	5 years	
	30%	S	1 year	Slight edge attack
	Conc.	U	1 day	Swollen
Tartaric acid	Saturated sol.	S	5 years	
Toluene		U	7 days	Dissolved
Trichloroethane		U	1 day	Dissolved
Trichlorethylene		U	1 day	Dissolved
Tricresyl phosphate		U	2 years	Attacked/crazed
Water		S	5 years	
White Spirit		S	5 years	Slight crazing
Xylene		U	7 days	Dissolved

**NOTE:**

**Chemical resistance tests are difficult to interpret accurately because plastics materials generally may be attacked in several ways. The table must therefore be used with discretion and should be supplemented by component tests under actual service conditions.**

## 15.0 TALK TO US

Tel: +44 (0)1254 874 000  
info@lucitesolutions.com  
www.lucitesolutions.com

Lucite International UK Ltd  
PO Box 34, Darwen  
Lancs BB3 1QB  
England  
Fax: +44 (0)1254 873 300

*MJL/October 2005*

*This document has been completely revised, superseding all previous editions and incorporating material from the now deleted publications PXTD 228, PXTD 230 and PXTD 244.*

*No part of this document, either text or graphics, may be reproduced in any form without written permission from Lucite International.*

*Values quoted for properties of Perspex<sup>®</sup> from Lucite<sup>®</sup> are results of tests on representative samples and do not constitute a specification.*

*Users of Perspex<sup>®</sup> are recommended to consult the appropriate Lucite International **MSDS** which is obtainable from your supplier. Users of other materials mentioned in this publication but not produced by Lucite International are advised to obtain Health and Safety information from the suppliers.*

*Information contained in this publication or as otherwise supplied to users is believed to be accurate and is given in good faith, but it is for the users to satisfy themselves of the suitability of the product for their own particular purpose. Lucite International gives no warranty as to the fitness of the product for any particular purpose and any implied warranty or condition (statutory or otherwise) is excluded except to the extent that exclusion is prevented by law. Lucite International accepts no liability for loss or damage (other than that arising from death or personal injury caused by defective product, if proved), resulting from reliance on this information. Freedom under Patent, Copyright and registered Designs cannot be assumed.*

*Perspex<sup>®</sup>, Lucite<sup>®</sup> and Tensol<sup>®</sup> are Trade Marks of Lucite International.*

*Our general selling conditions apply.*

*© Lucite International UK LTD 2005.*

## 16.0 APPENDIX

### 16.1 LIST OF SUPPLIERS

#### **C. R. Clarke & Company (UK) Ltd**

Betws Industrial Park  
Ammanford  
Carmarthenshire SA18 2LS  
United Kingdom  
Tel: +44 (0)1269/590530  
Fax: +44 (0)1269/530540

#### **Bostik Ltd**

Ulverscroft Road  
Leicester  
LE4 6BW  
United Kingdom  
Tel: +44 (0)116/268 92 54  
Fax: +44 (0)116/628 92 99

#### **Pacer Systems Ltd**

Gauntley Street  
Nottingham  
PNG7 5HFP  
Tel: +44 (0)115/988 77 77  
Fax: +44 (0)115/988 77 88

#### **Spandex PLC**

1600 Park Avenue  
Aztec West  
Almondsbury  
Bristol BS12 4UA  
United Kingdom  
Tel: +44 (0)1454/616 444  
Fax: +44 (0)1454/616 777